



Prescott Series Operation & Maintenance Manual

Table of Contents

ST. CROIX FEATURES	2
INSTALLATION	3
PREVENTING CHIMNEY FIRES	3
SATISFACTORY PERFORMANCE.....	3
APPROVED FUELS	3
Pellets, Cherry Pits & Pellet /Corn mix	3
OPERATING INSTRUCTIONS.....	4
Control Board Features.....	4
Thermostat Function – How does it work?	5
Pre-Lighting Instructions.....	6
Lighting Your Stove	6
Shutting the Stove off	6
Diagnostic Features.....	6
Safety Features.....	7
Combustion Air Damper	8
Flame Pattern Characteristics	8
MAINTAINING THE STOVE	9
Daily Maintenance	10-11
Periodic Maintenance	11-12
Yearly Maintenance	13-14
SAFE OPERATION	15
TROUBLESHOOTING AND FAQ.....	16-20
PARTS LAYOUT	21-22
WARRANTY.....	23

Combustion Air Damper

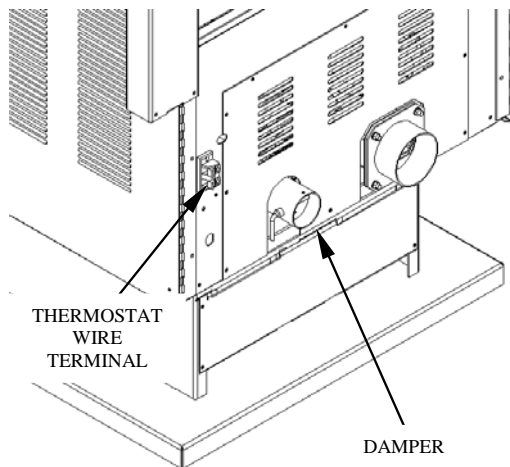

Figure 3

Damper Adjustment

When burning pellets make sure to check for the formation of creosote in the unit and venting system. Constantly running the stove on a low setting with too much combustion air may cause creosote to form. Burn pot temperatures can be “too cool” when burning on low with too much draft.

Adjusting the Damper may take a little time and patience, but only needs to be done once. After the damper has been adjusted to the venting system in your home, the control board will do the rest.

The purpose of this damper is to adjust combustion airflow to match the characteristic of each specific air inlet and chimney configuration. There is a setscrew in the damper (*shown in Figure 4*) and the damper has been preset at the factory. This setting will most likely work for 90% of the most common installations. Long horizontal runs might need the damper opened. Tall vertical runs might need the damper to be closed a little, etc. To adjust the damper, use the setscrew to make the adjustments. To make an adjustment turn the screw $\frac{1}{2}$ turn clockwise to open the damper or $\frac{1}{2}$ turn counter clockwise to close the damper. Remember to use the damper handle to bring the damper up to the screw. The damper will not close by itself. After making an adjustment wait at least 15 minutes to see how the burn pot reacts to the change. **Adjusting the damper during the break in period is very**

important (See “Preventing Chimney Fires” on page 2). Break-in requires the burning of 15 bags of pellets or continuous burn for two weeks. If during the initial break-in period you experience difficulty keeping the stove burning or there appears to be an excessive amount of burning pellets being evacuated from the burn grate, it may be necessary to close the damper some more. Once the damper is fine tuned for settings 1, 2, 3 and 4 the stove will run fine without having to make a change to the damper setting unless the stove is run on 5 for extended periods of time. It is normal for ash and some sparks to be continually evacuated from the burn grate. This is how the grate continuously cleans itself. The equivalent of a teacup of unburned pellets a day in the ash pan is considered normal.

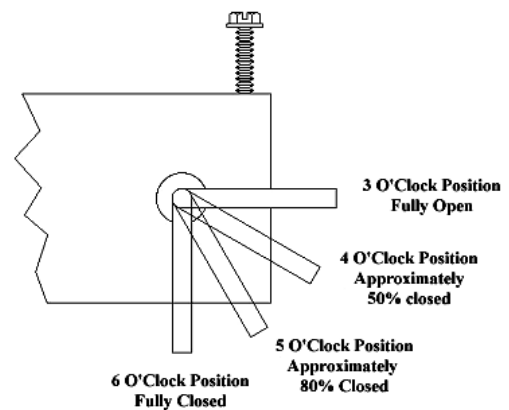

Figure 4

Flame Pattern Characteristics

Correct Flame Pattern - Bright yellowish-white flame with a brisk movement, having sharp pointed end tips extending up towards the Heat Exchange Tubes while forming a fan-like shape. Small amounts of ash and some live sparks being blown out from the Burn Pot area is considered normal operation.

Incorrect Flame Pattern - Dark orangish-brown flame with a lazy movement, having black smoky end tips curling up and over the Heat Exchange Tubes while forming a fireball-like shape. Some Ash or Live Sparks not being blown out from the Burn Pot area is considered abnormal operation. Extremely black soot forming on the ceramic glass surface is a sign of very poor combustion (not enough combustion air) and should not be overlooked. At the other end of the spectrum; an

extremely brisk flame which blows large pieces of live coal out from the Burn Pot area and causes stubborn shiny black build-up on the glass (too much combustion air) is also considered undesirable. **If you experience problems adjusting the stove during the Break-In Period, contact your dealer.**

MAINTAINING THE STOVE - The stove requires a minimum amount of daily maintenance. Required maintenance depends largely upon the quality of pellet fuel burned and the rate of burn. The amount of daily maintenance will increase if fuel quality decreases and/or the burning rate of pellets increases.

NOTE: FAILURE TO KEEP YOUR STOVE CLEAN, AS DESCRIBED IN THIS MANUAL, COULD RESULT IN POOR OPERATION, INEFFICIENT FUEL USAGE AND A POSSIBLE SAFETY HAZARD! IT IS YOUR RESPONSIBILITY TO DETERMINE NEEDED MAINTENANCE FREQUENCY.

The Versa Grate System (see Figure 5 below). The benefit of this feature is that the stove can operate for longer periods of time, with most

fuels, without the grate requiring cleaning. If the flame becomes dark orange, is accompanied by black smoke or burns with a lazy motion - it's time to clean the grate **When you first operate your stove or whenever you change fuels check to determine needed cleaning frequency.**

First, let's become familiar with the burn system in a St. Croix Pellet stove. Remember, cleaning frequency may change dramatically from one fuel to another. Pellets with high ash content or that have increased amounts of impurities or high moisture content. Every St. Croix Pellet stove model will have the same system as shown in figure 5 below. There is a 2-piece burnpot. The top Part is called the **"Grate Weldment"**. This sits on top of the **"Shaker Plate"**. This in turn sits on top of the **"Shaft/Cage Weldment"** and is held in place with the **"Spacer"** & **"Self Locking Twist pin"**. The Shaft/Cage weldment is moved towards the front of the stove and then towards the back of the stove by the **"Cam"** that is connected to the **"Versa Grate Motor"**. This motion is constant, while the stove is in operation. The only parts that may need to be removed for cleaning purposes during the Daily or Periodic Maintenance are the **"Grate weldment"** and the **"Shaker Plate"**. This is to check the holes in the burnpot system to see if they are plugged.

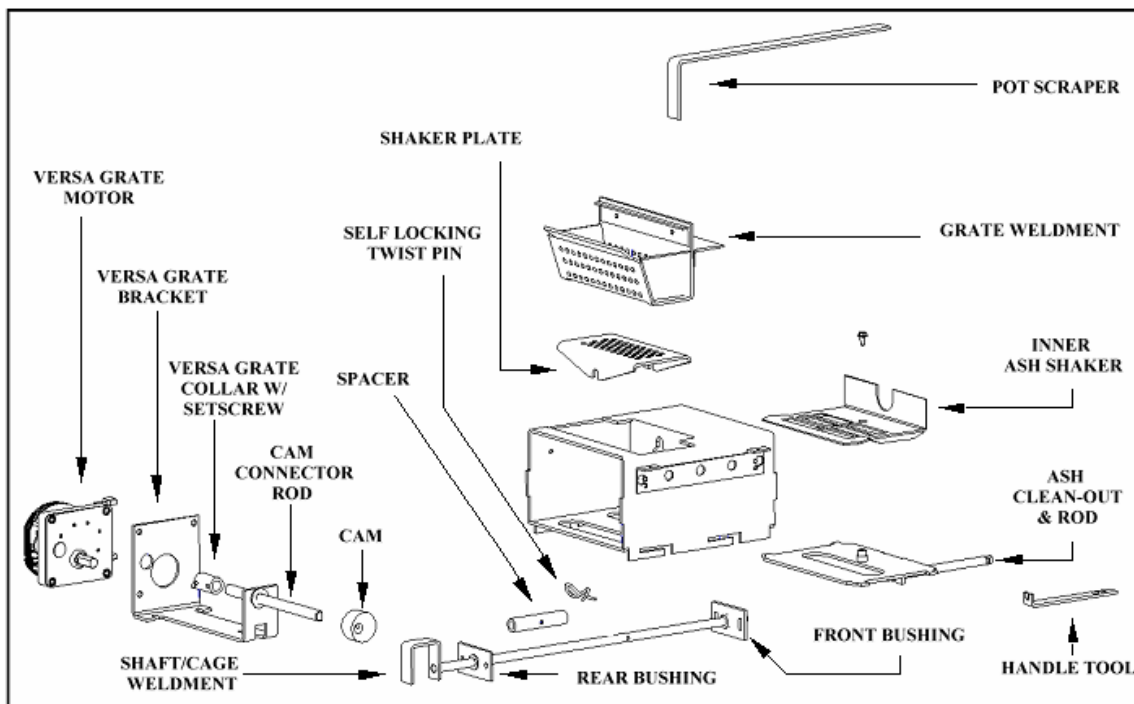

Figure 5

Daily Maintenance

1. Check Grate Weldment and Shaker Plate (See figure 5) to determine if holes are plugged. Clean as needed. With proper precautions the grate may be partially cleaned while the stove is hot. Follow these steps:

CAUTION: THE DOOR AND FRONT PART OF THE STOVE WILL BE HOT. DO NOT TOUCH ANY PART OF THE STOVE THAT IS HOT!

- Wear a leather glove that covers the lower arm.
- Turn the Stove to Heat Level 1 and allow the flame to burn down to a low burn.
- Open the firebox door slowly to prevent drawing ash or odors into the room.
- Use the “scraper” provided to move the burning pellets to one side of the grate, leaving the ash in the bottom of the grate. (See Fig 5 & 6)
- Rake the ash & clinkers out over the grate into the ash pan.
- Rake the burning pellets across the bottom of the grate.
- Close the door.
- Re-select the desired heat setting.

CAUTION: NEVER ADD FIRE STARTER TO A HOT STOVE.

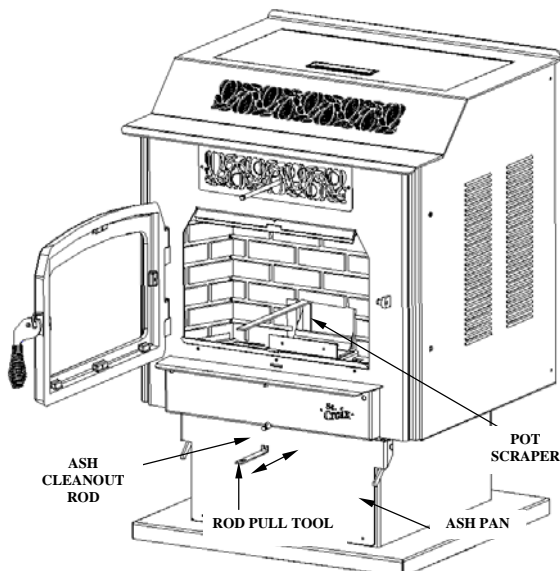

Figure 6

2. Remove ash buildup under the grate bottom daily or as frequently as needed. Clean the ashes out from under the burn pot by pulling the Ash Cleanout Rod in and out several times (see Fig. 6) Use the Rod Pull Tool with the Ash Cleanout Rod. This tool is hanging on a screw on the back of the stove; this provides a convenient location to keep the tool in reach and prevent it from getting lost.

CAUTION: The Ash Cleanout Rod must be pushed all the way in during operation of the unit. Failure to keep this area clean could result in a safety hazard.

3. Check ash pan (See Fig. 6) to determine emptying frequency needed. NOTE: Do not use a vacuum cleaner for this purpose. Hot coals may cause your vacuum filter to catch fire. Place ashes in a metal container with a tight fitting lid. The closed container of ashes should be placed on a noncombustible floor or on the ground, well away from all combustible materials, pending final disposal. If the ashes are disposed of by burial in soil or otherwise locally dispersed, they should be retained in the closed container for at least two days until all cinders have thoroughly cooled.

4. Once or twice daily pull the Heat Exchange Tube Scraper, (*See stove layout on page 2*) out and back to clean heat exchange tubes. Failure to operate the tube scraper daily may result in poor combustion and loss of heat output. This should be done when the stove is cool or operating on the low temperature setting. Use the Rod Pull Tool shown in Figure 6 with the Tube Scraper Rod.

5. The rate of burn and the quality of fuel will determine how often the window needs cleaning. Prolonged burning at a slow burn rate will result in the need for more frequent window cleaning. Burning poor fuel also increases the need to clean the window. Cooling the stove and wiping the window daily with a cloth or paper towel will normally keep the window from accumulating difficult to clean residue. Use of a glass cleaner ONLY permitted when the stove is cold. *Tip: Dip the damp towel in the ashes to remove stubborn buildup on the glass.*

CAUTION: Do not slam the door. Do not operate the stove with a broken or cracked glass. Replace only with heat resistant ceramic glass supplied by the manufacturer.

6. Burn the stove at the HI fuel setting for at least 20 to 30 minutes each day. This helps keep the window, ceraboard and firebox area clean. A daily high burn also aids in maintaining the overall efficiency and performance of the stove.

Periodic Maintenance

CAUTION: Periodic maintenance should only be done while the stove is shut off and cold.

1. Empty the ash pan when it appears full. This may range from 1 to 2 weeks in the Prescott EXP model. The Prescott EXL model has a much smaller ashpan and should be checked at least twice a week. The frequency of cleaning the ash pan will depend on the quality and amount of pellets being used. Carefully check to make sure the ash pan door is tightly closed after each opening.
2. The Prescott models have 3 Exhaust Cleanout/Ash Trap covers, 2 of which are located below the rear brick panel and a 3rd Clean Out is located behind the Ash Pan. Remove covers and clean regularly. (See stoves shown in Figure 7) Be sure to clean both sides.

Use scraper shown in figure 5 & 6 to scrape ash into ash pan. Use a vacuum (cold stove only) to thoroughly clean these areas.

IT IS CRITICAL THAT YOU KEEP ASH CLEAN OUTS CLEAN FOR SATISFACTORY PERFORMANCE.

Frequency of cleaning Ash Traps depends on the amount of fuel being burnt and the quality of the pellets. Fuel with low ash content is recommended.

Failure to clean the ash traps can cause the stove to become plugged with fly ash and could result in a Safety Hazard.

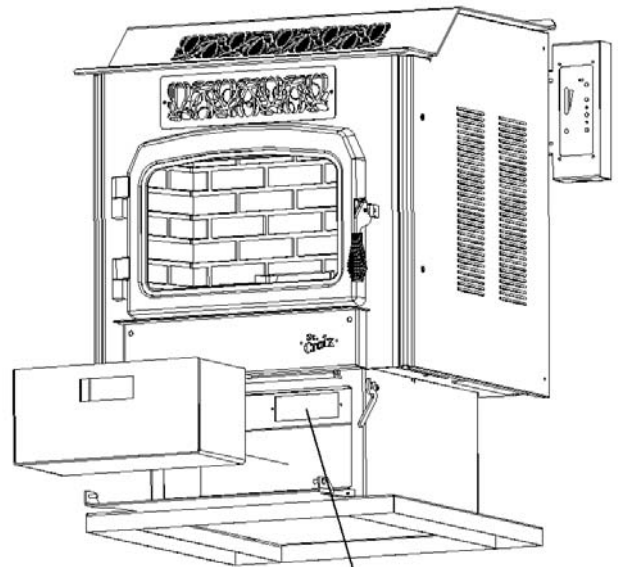

THE LOCATION OF THE THIRD CLEAN-OUT/ASH TRAP BEHIND THE ASH PAN IN A PRESCOTT EXP

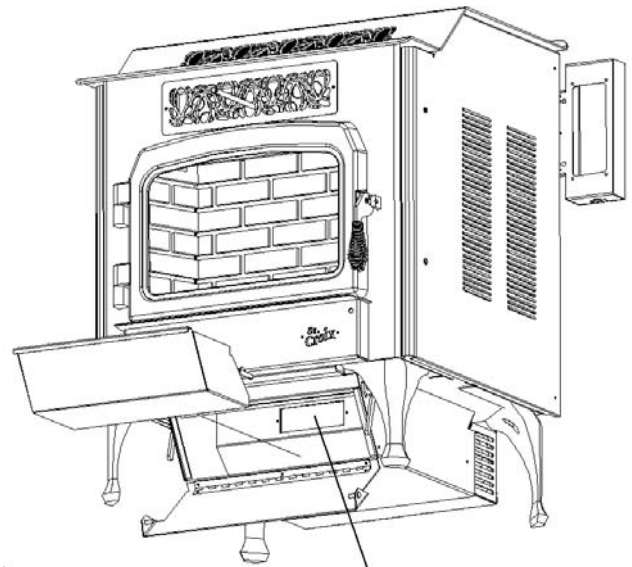

THE LOCATION OF THE THIRD CLEAN-OUT/ASH TRAP BEHIND THE ASH PAN IN A PRESCOTT EXL

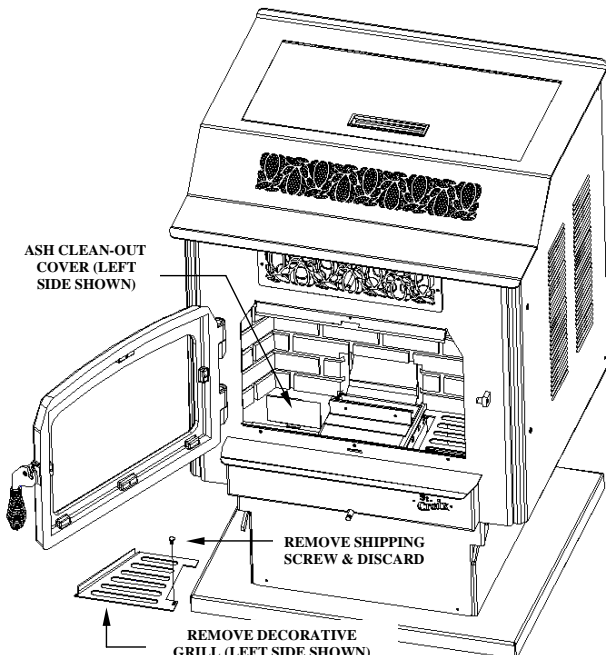

ASH CLEAN-OUT COVER (LEFT SIDE SHOWN)

REMOVE SHIPPING SCREW & DISCARD

REMOVE DECORATIVE GRILL (LEFT SIDE SHOWN)

Figure 7

3. Clean burn grate holes at least weekly. Remove the burn grate and use a small metal object to clean out plugged holes. (See fig. 5 on page 9.)

4. Remove the baffle and clean the ashes that accumulate on a regular basis.

Frequency of cleaning depends on amount of fuel being burnt and the quality of the pellets. Fuel with low ash content is recommended.

Failure to clean the baffle can cause the stove to become plugged with fly ash and could result in a Safety Hazard.

To remove the baffle (See Figure 8), lift the back of the baffle up to clear the inner back of the stove and slide towards the front of the stove. The baffle will slide out of the keyhole slots and drop down. *When putting the baffle back in the stove, make sure the screws are in the keyhole slots and the back of the baffle is lifted up over the inner back.*

4. Periodic cleaning of the exhaust system is required. Under certain conditions creosote buildup may occur rapidly. Low quality pellets and poor installations require more frequent chimney cleanings. **See Page 3 “Preventing Chimney Fires”.** The products of combustion will also contain small particles of fly ash. The fly ash will collect in the exhaust vent and restrict the flow of the flue gases. Judge the frequency of cleaning by checking the amount of ash that accumulates in the elbows or tee’s of the exhaust system. Ask the dealer for suggested frequency of cleaning, equipment needed and procedures for cleaning. Check the exhaust system at least once every two months during the heating season.

Periodically inspect the condition of the rope gasket around the door, window and ash door. Replace as needed.

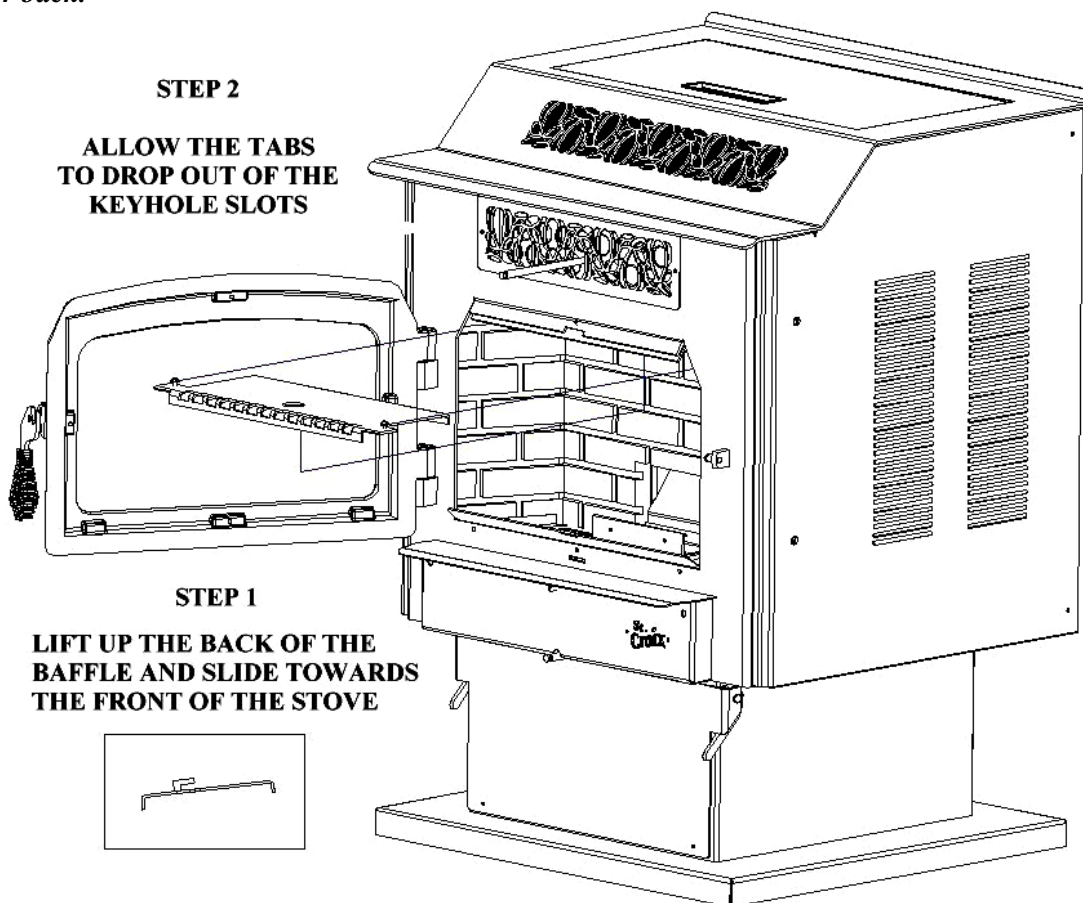

Figure 8

Yearly Maintenance

Yearly maintenance is designed to assure safe operation, prolong the life of the stove and help preserve its aesthetic appeal.

1. **Spring Shutdown.** After the last burn in the spring, cool the stove. Remove all pellets from the hopper and the auger. Thoroughly clean the burn grate, burn grate box, ash pan and ash traps behind the ash pan. (*To locate the ash traps see Figure 7 on page 11*)

NOTE: UNPLUG THE STOVE. Open the side panels of the stove. Carefully clean or vacuum any sawdust, cobwebs and household dust.

Carefully vacuum around the fan motors. If electrical wires become disconnected call your dealer for service.

2. The exhaust system should be thoroughly cleaned at least annually. Call your dealer for this service.
3. The motor/fan area behind the firebox and under the hopper should be vacuumed annually.
4. The Exhaust and Room fans should be removed and cleaned annually. Call dealer for this service. Annual oiling of the motors is not needed. (See fig. 8)

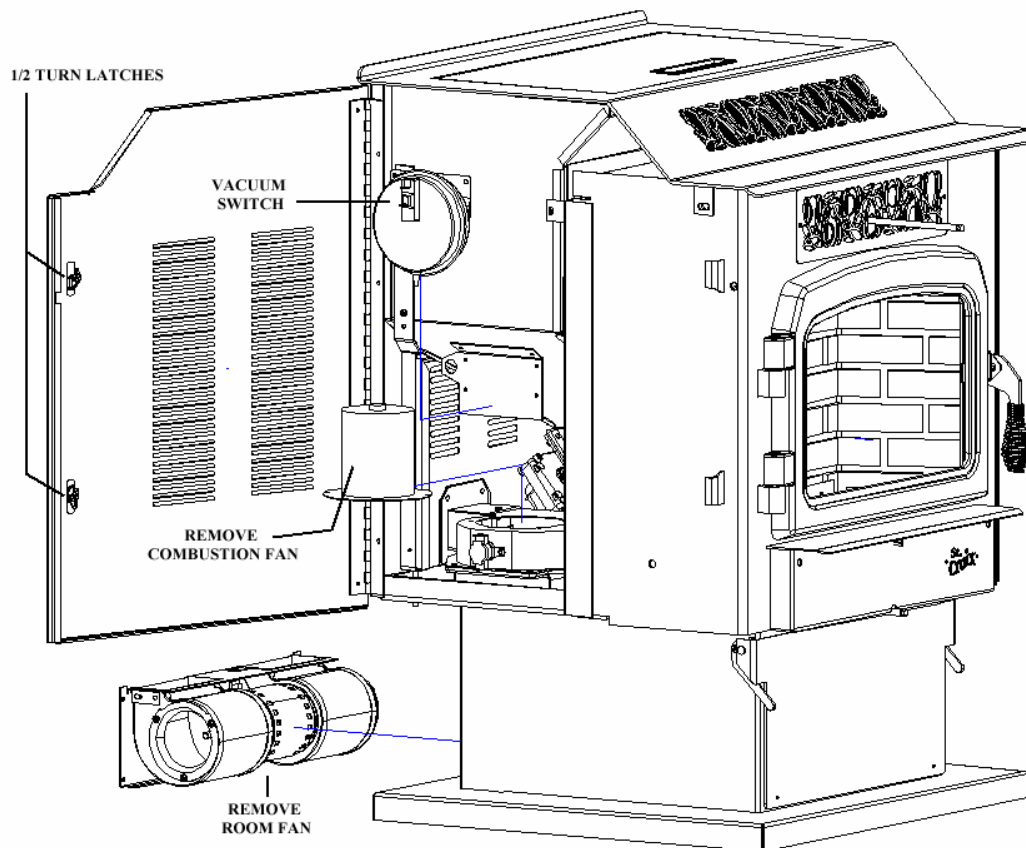

Figure 9

Note: The Vacuum Switch may be removed to allow easier access to the combustion fan